



R32

**AIR CONDITIONER (SPLIT TYPE)
INSTALLATION & OWNER'S MANUAL**

ENGLISH

ภาษาไทย

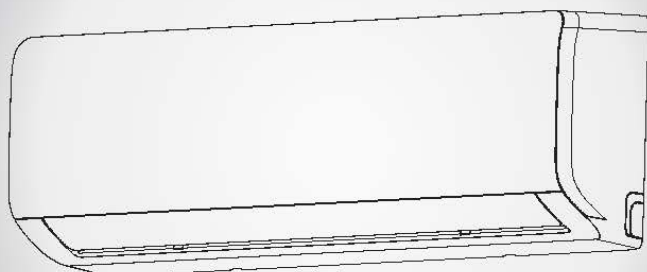

**Indoor unit
42NVAA010, 013, 018, 024**

**Outdoor unit
38NVAA010, 013, 018, 024**

Dear users:

Thank you for purchasing our products. Before installing, operating, maintaining, and troubleshooting, please read this Manual carefully to fully understand and use this product correctly.

To install and operate this product correctly and safely, please observe the following instructions:

- **Please strictly follow the provisions in this Manual.**
- **All the illustrations in this Manual are for explanatory purposes only, and the appearance and functions shown may be different from those of the product you purchased. To make the products better, our company will constantly improve and innovate without prior notice.**
- **Your product shall be cleaned and maintained regularly to improve its performance and prolong its service life. Don't hesitate to get in touch with your local dealer before each air conditioning season. Our company will arrange for professional maintenance personnel to provide you with paid services, including cleaning, maintenance, inspection, and maintenance.**
- **After reading this Manual, please keep it properly for future reference.**

STATEMENT



- ① The diagrams in this Manual are for illustration only, and the actual product shall prevail.
- ② Please read this Manual carefully before use. Otherwise, improper operation may damage the product or endanger the personal and property safety of you or others. The product is subject to upgrades or changes without prior notice.

CONTENTS

Safety Warning

- Description of warning signs01
- Precautions02
- Electrical Safety Requirements03

Product Introduction

- Component Description04
- List of accessories04
- Locally procured components05

Instructions for Use

- Electrical Safety Requirements06
- Operating range08

Instructions for Installation

- Installation and Maintenance Precautions08
- Indoor Unit Installation16
- Outdoor Unit Installation22
- Electrical Installation31
- Test Run34

Maintenance

- Cleaning of the filter and air cleaner35
- Cleaning of the air outlet and external panel36
- Maintenance37

Appendix

- Instruction Manual for Remote (NT-02)38

Safety Warning







The unit must be effectively grounded.

Incorrect operation may cause serious damage to the unit or injury or even death to the user, or result in electrical hazards or fires.

For the contents and importance of safety notes described in this Manual, please read the main text based on fully understanding the following signal words, and observe the safety notes to prevent personal injury or property damage to users or others.

■ Description of warning signs

Signal words (DANGER, WARNING, and CAUTION) are used to identify levels of hazard seriousness. Definitions for identifying hazard levels are provided below with their respective signal words. Please fully understand the following signal words, each of which is extremely important to ensure safety.

 DANGER	Indicates a hazardous situation that, if not avoided, will result in serious injury or even death.
 WARNING	Indicates a hazardous situation that, if not avoided, could result in serious unit damage, serious personnel injury, and even death, or an electrical hazard or fire.
 CAUTION	Indicates a hazardous situation that, if not avoided, could result in minor personal injury and damage to unit and property.
 TIP	Some useful operation and maintenance information.

WARNING CONTENT



Professionals required



Effective grounding required

PROHIBITED INSTALLATION LOCATIONS



Flammable materials prohibited



No strong current



No open flames



No acid-base substances

Please read this Manual carefully before operating and installing the unit, and keep it properly for future reference

■ Precautions

CAUTION

The equipment contains fluorinated greenhouse gas R32

Global Warming Potential(GWP):675



- Please read the manual before installation, use or maintenance!
- The room area where flammable refrigerant air conditioners are installed, operated, and stored needs to meet the area specified in the Installation and Operation Manual.
- A vacuum pump must be used for the evacuation operation; evacuation using refrigerant from the unit itself is strictly prohibited.
- If the air conditioner leaks refrigerant, no smoking or open flames are allowed. Immediately open all doors and windows to keep the room well-ventilated, turn off the power, and call for repair after leaving the room.
- Compliance with national gas regulations is required.
- Do not puncture or ignite the air conditioner.
- The air conditioner must be stored securely to prevent accidents that could result in personal injury or casualties.

According to IEC 60335-2-40:2013/AMD1:2016 (Appendices GG.4/GG.5), the charging limit requirements for R32 refrigerant and the required room area for air conditioner installation are as follows:

Table Maximum charge mass (kg)

Type	LFL (Lower Flammable Limit) kg/m ³	h ₀ (Installation height of the air conditioner) /m	Minimum Room Area /m ²						
			4	7	10	15	20	30	50
R32	0.306	0.6	0.68	0.90	1.08	1.32	1.53	1.87	2.41
		1.0	1.14	1.51	1.80	2.20	2.54	3.12	4.02
		1.8	2.05	2.71	3.24	3.97	4.58	5.61	7.24
		2.2	2.50	3.31	3.96	4.85	5.60	6.86	8.85

Table Minimum Room Area (m²)

Type	LFL (Lower Flammable Limit) kg/m ³	Total charge mass/kg	1.836	2.448	3.672	4.896	6.12	7.956
			Minimum Room Area /m ²					
R32	0.306	0.6	29	51	116	206	321	543
		1.0	10	19	42	74	116	196
		1.8	3	6	13	23	36	60
		2.2	2	4	9	15	24	40

DANGER

- During thunderstorms, please disconnect the main power switch; otherwise, lightning may damage the unit and cause accidents.

WARNING

- This air conditioner may be used by children aged 8 years and above, and persons with reduced physical, sensory, or mental capabilities, provided they are supervised or have received guidance on safe operation of the air conditioner and understand the associated hazards. Children must not play with the air conditioner. Children must not perform cleaning and maintenance without supervision.
- The installation of the air conditioner must comply with local standards, electrical codes, and the installation requirements specified in this Manual.
- Do not use a liquid cleaning agent, liquefied cleaning agent, or corrosive cleaning agent to wipe the unit or sprinkle water or other liquids on the unit. Otherwise, the plastic parts on the unit will be damaged, and electric shock may occur in severe cases. Turn off the main power before cleaning or maintaining the unit. Otherwise, accidents may occur.
- When the air conditioner needs to be removed and reinstalled, please contact the dealer and have it handled by a professional maintenance personnel.
- For maintenance and repairs, please contact the dealer and have them performed by professional maintenance personnel.

■ Electrical Safety Requirements

WARNING

- The air conditioner must be installed in accordance with local wiring regulations.
- Conduct the wiring only by a qualified electrician.
- Perform the wiring according to electrical safety specifications.
- Ensure that the unit is well grounded; that is, the main switch of the unit must have a reliable ground wire.
- Cut off all power supplies before touching the wiring device.
- Do not disassemble or repair the unit by yourselves. Otherwise, it may be dangerous. If there is a fault, cut off the power supply immediately, and then contact the local dealer.
- Provide the unit with a separate power supply that meets the rated parameters.
- Install a power supply disconnecter for the fixed wiring of the unit according to the wiring specifications.
- If the power cord is damaged, it must be replaced by a professional maintenance personnel to avoid hazards.

CAUTION

- Do not disconnect the ground wire of the main power switch under any circumstances.
- Do not use damaged power cords and replace them immediately if damaged.

Product Introduction

■ Component Description

Indoor Unit

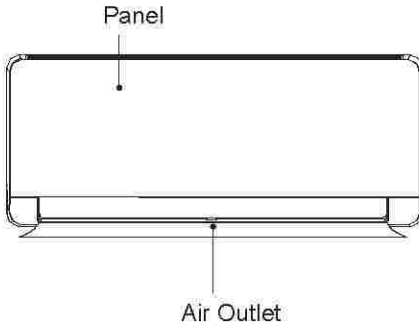

Outdoor Unit

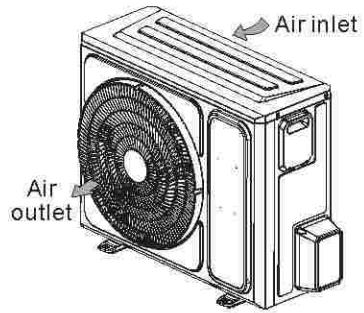



Remote Control (standard configuration)



Front

■ List of accessories

Accessory Name	Quantity	Shape	Purpose
Installation and User Manual	1		(Please be sure to give to the user)
Warranty card	1		(Please be sure to give to the user)
Copper nut	2		For connecting copper pipes
Air cleaner	1		For filtering impurities in the air (non-reusable)
Cross recessed flange head tapping screw	5		For mounting plate

Remote control	1		Air conditioner adjustment
Remote control battery	2		For remote control
Remote control holder	1		For placing the remote control
Cross recessed countersunk head tapping screw	2		For fixing the remote control holder

■ Locally procured components

Copper pipe	Model	42NVAA010, 013 38NVAA010, 013	42NVAA018 38NVAA018	42NVAA024 38NVAA024
	Liquid side piping (mm)	$\Phi 6.35 \times 0.8$	$\Phi 6.35 \times 0.8$	$\Phi 9.52 \times 0.8$
	Gas side piping (mm)	$\Phi 9.52 \times 0.8$	$\Phi 12.7 \times 0.8$	$\Phi 15.88 \times 1.0$
	For the connection of the refrigerant system between the outdoor unit and the indoor unit, it is recommended to use soft copper pipe, the length of which meets the requirements of the section [Allowable length and height difference of refrigerant piping] in the chapter "Instructions for Installation"			
Insulation sleeve	Refrigerant-side pipeline: Copper pipe outer diameter $\leq \Phi 12.7$, insulation thickness not less than 8 mm; Copper pipe outer diameter $\geq \Phi 15.88$, insulation thickness not less than 8 mm; Thicker insulation should be used in cold regions.			
Rubber cement	Apply to the gap between the through-wall pipe hole and the connecting pipes.			
Drain pipe	For draining the condensed water.			
Through-wall pipe cover assembly	For decorating the through-wall pipe hole.			
Vinyl tape	For bundling the connecting wires and pipes.			

 TIP

- All optional accessories must be genuine parts provided by the Company.
- The purchased copper pipes must meet the following requirements: It is necessary to use seamless copper pipes which are made of either copper or copper alloy and it is desirable that the amount of residual oil is less than 40 mg/10 m. Do not use copper pipes having a collapsed, deformed or discolored portion (especially on the interior surface). Otherwise, the expansion valve or capillary tube may become blocked with contaminants. At the same time, the wall thickness of the purchased copper pipes must not be less than the thickness specified in the table above.
- All illustrations in this Manual are for explanatory purposes only. The appearance and functions depicted may not exactly match those of the product you purchased. Please refer to the actual product for details.

Instructions for Use

■ Electrical Safety Requirements

 CAUTION

- If the unit will not be used for an extended period, please disconnect the main power switch to prevent accidents.
- The indoor unit of the air conditioner should be installed at least 2.5 meters above the ground to avoid the following risks:
 - a. Non-professionals who come into contact with moving or live parts (such as fan wheels, motors, air guides, etc.) may cause injury to you or damage to the transmission components during operation.
 - b. Being too close to the air conditioner may cause discomfort.
- When used together with combustion appliances, regular ventilation is required; otherwise, it may lead to insufficient oxygen supply.
- Do not insert fingers or any objects into the exhaust outlet or intake grille.
- Do not allow the indoor unit or controller to get wet or damp, as this may cause short circuits or fire.
- Do not place combustion appliances directly in the air conditioner's airflow, as this may cause incomplete combustion.
- Never use or store flammable gases or liquids such as natural gas, hair spray, paint, or gasoline near the air conditioner, as this may cause a fire.
- Never place plants or animals directly in the air conditioner's airflow to avoid harm to them.
- If any abnormal conditions occur, such as unusual noise, odors, smoke, temperature rise, electric leakage, etc. Please immediately cut off the power supply and contact your local dealer. Do not attempt to repair the air conditioner yourself.

- Do not place flammable sprays near the air conditioner or spray them directly towards it, as this may cause a fire.
- Do not place containers of water on the air conditioner, as water seeping into the interior can reduce electrical insulation and cause electric shock.
- After long-term use, please check whether the installation base is worn. Placing the air conditioner on a worn base may lead to unit detachment, resulting in personal injury or fatalities:
- Do not operate the switch with wet hands, as this may result in electric shock.
- During maintenance, be sure to stop operation and disconnect the power supply; otherwise, the high-speed rotation of internal components such as the fan wheel may cause personal injury.
- The unit is a comfortable type, which shall not be used in computer rooms and special places for storing precision instruments, food, animals and plants, artworks, etc.
- Never use fuses other than those specified in this Manual, such as iron or copper wires, as this may result in air conditioner malfunction or fire. The power supply must be a dedicated circuit for the air conditioner within the permitted voltage range.
- Do not place valuable items beneath the air conditioner, as condensation water may form under certain fault conditions, potentially damaging the items below.

CAUTION

- To ensure normal operation of the unit, please use it according to the chapter "Instructions for Use" in this Manual. Otherwise, it may trigger internal protection, cause water dripping, or reduce cooling performance.
- Please set the room temperature to a moderate level, especially when there are elderly people, children, or patients in the room.
- Lightning strikes or the switching on/off of large electrical equipment nearby may cause malfunctions in the air conditioner. In such cases, disconnect the main power switch for several seconds, then turn it back on and restart the air conditioner.
- The air conditioner must not be powered through an external switching device, such as a timer or a circuit that is turned on and off by a general-purpose timer.
- Check that the air filter is properly installed and ensure that the indoor and outdoor units' air inlets and outlets are not blocked.
- If the air conditioner has not been used for a long time, please clean the air filter before turning on the unit. Otherwise, accumulated dust and mold on the filter may cause air pollution or unpleasant odors. For detailed instructions, refer to the "Maintenance" section.

■ Operating range

This product is a T1 Type room air conditioner. According to the current standard TIS1529-2561, its normal operating ambient temperature range for cooling is 0°C ~ 50°C.

For safety and optimal performance, please operate the air conditioner within the following temperature conditions:

Cooling Operation	Outdoor Ambient Temperature	0°C ~ 50°C
	Indoor Set Temperature	16°C ~ 32°C

Installation Instructions

This air conditioner must be installed or relocated by professionals.

During the installation of this product, please ensure that the personal protective equipment (PPE) of the installation personnel complies with local regulatory requirements.

■ Installation and Maintenance Precautions

TIP

- This section marked with "" applies to products using flammable refrigerants.

1) Check the user's power circuit, grounding, and other electrical safety conditions to ensure compliance with local electrical safety regulations and requirements.

- The air conditioner should be installed in accordance with local wiring regulations and must be powered by a dedicated electrical circuit to prevent overheating or short circuits caused by circuit overload, which could lead to fire.

2) When the air conditioner's maximum current is ≥16 A, an air-break switch with protective function or a leakage protection switch must be used.

3) The mounting bracket and installation requirements that must be followed.

- The mounting bracket must meet the strength requirements specified in relevant local or industry standards, and all welds and connections must be treated for rust prevention;
- The strength of the mounting bracket and the supporting surface must be more than four times the weight of the unit, and at least 200 kg;
- The outdoor unit mounting bracket must be secured using metal expansion bolts;
- Ensure the reliability of the wall mounting to prevent falling, which could cause damage or injury;
- The outdoor unit and heat pump unit must be secured with anti-tipping components to prevent overturning, which could cause damage or injury.

4) The installation location selection requirements that must be followed (the following is the basis for installation location selection; please obtain the consent of the user and property management).

- Avoid locations where flammable or explosive gases may leak or where there is a strong presence of corrosive gases;
- Avoid locations subject to strong electrical or magnetic fields;

- Avoid locations prone to noise and vibration;
- Avoid locations with harsh natural conditions (such as heavy grease fumes, high sand/dust, or sources of high heat);
- The outdoor unit should be installed in a location inaccessible to children;
- Select a location that is convenient for maintenance, inspection, and ensures good ventilation;
- Ensure sufficient space for maintenance and care, and install the indoor unit at a height between 230 cm and 260 cm above the floor;
- The outdoor unit must not occupy public areas of the building, such as corridors, stairways, exits, fire escape routes, or pedestrian pathways;
- The outdoor unit should be installed as far away as possible from neighboring windows, doors, and greenery.

5) When working at heights, a safety harness must be worn, the outdoor unit must be securely fastened with a rope of sufficient strength, and warning signs must be posted.

- When performing installation work at a height of 2 meters or more above the fall reference level, installers must wear safety harnesses, securely fasten the outdoor unit with ropes of sufficient strength, and set up warning signs to prevent falls of personnel or equipment that could result in personal injury, fatalities, or property damage.

6) Ensure proper grounding is reliably established.

- The air conditioner is a Class I household appliance; the grounding wire of the power supply circuit must be securely connected to the air conditioner's grounding terminal;
- The air conditioner's grounding wire must not be connected to gas pipes, water pipes, lightning rods, telephone lines, or any circuit where the grounding wire has poor contact with the earth grounding electrode;
- The yellow/green striped wire is for grounding only and must not be used for any other purpose;
- The resistance between the grounding terminal and accessible metal housing must be less than 0.12Ω , and the grounding system's grounding resistance must be less than 4Ω .

7) Unpacking inspection 

- The product should be unpacked and checked in an open, well-ventilated area near the user's installation location, such as an open balcony or a well-ventilated stairwell. Open flames and smoking are strictly prohibited within 2 meters of the inspection area.
- Check the indoor unit carefully for any signs of impact or damage, and check that the appearance is normal. If nitrogen is sealed inside the indoor unit, when removing the seal from the connecting pipe port, if no sound of nitrogen escaping is heard, perform an airtightness check on the indoor unit's refrigerant system. The method is to reseal the pipe port at the indoor unit's connecting end, then charge nitrogen at 0.05 MPa – 0.08 MPa (gauge pressure) from the other end. After pressurizing for 3 minutes, check for any pressure drop.
- Before unpacking the outdoor unit, prepare a flammable refrigerant concentration detector. Open a small slit in the sealing tape, insert the detector into the container to check for refrigerant leakage. If leakage is detected, carefully cut open the sealing tape to allow any residual refrigerant gas inside the container to vent. Inspect the outdoor unit for leaks, and rule out false alarms caused by small amounts of residual refrigerant from manufacturing. If a leak in the outdoor unit is confirmed, the unit must be returned to a service center for further inspection and repair.

8) Installation Environment Inspection

- Before starting work, check the environment around the air conditioner to ensure there are no flammable materials or fire hazards.
- Before installing the air conditioner, check whether the indoor area meets the requirements specified in the installation manual. The indoor area must be \geq the minimum room area required by the installation manual. If the minimum room area requirement specified on the technical parameters page of this Manual is not met, installation must be refused, and the user must be informed accordingly.
- The installation area must have sufficient ventilation; it is prohibited to close all doors and windows.

9) Installation process control

- The use of open flames is prohibited during operation, including welding and smoking. Mobile phones must not be used. Inform the user not to cook with open flames, and it is recommended to keep the household appliances turned off (such as televisions, microwave ovens, etc.).
- Anti-static measures should be taken when installing the product during dry seasons.
- If flammable refrigerant leakage is detected in the indoor unit during installation, all doors and windows must be opened immediately to ensure adequate ventilation of the room. At the same time, immediately close the valves on the outdoor unit. All personnel should leave the indoor area. Wait at least 15 minutes after the refrigerant has fully leaked before proceeding with any handling or operations. If the product is already damaged, it must be returned to a service center for repair. Operations such as refrigerant pipe welding are prohibited at the user's location.

10) Qualification requirements for maintenance personnel

- All operators or maintenance personnel for refrigerant circuits must hold a valid certificate issued by an industry-recognized accreditation body certifying that they possess the qualifications required by industry-recognized standards for the safe handling of refrigerants;
- Maintenance and repair of the equipment must be carried out only using the methods recommended by the equipment manufacturer. If assistance from other professionals is required for maintenance and repair, it must be carried out under the supervision of personnel qualified to handle flammable refrigerants.

11) Inspection of the site

- Before performing maintenance on an air conditioner using flammable refrigerant, a safety inspection must be conducted to minimize the risk of fire. When repairing the refrigeration system, the precautions described below must be observed before performing any operations on the system.

12) Operating procedures

- Operations must be carried out under controlled procedures to ensure that risks caused by flammable gases or vapors are minimized during the work process.

13) General operating area

- All maintenance personnel and other individuals within the work area should be aware of the nature of the work being performed. Avoid operation in enclosed spaces. The work area should be properly isolated, and the flammable materials should be controlled to ensure safe working conditions within the area.

14) Check for the presence of refrigerant

- Appropriate refrigerant detectors should be used to monitor the area before and during the operation, ensuring that technicians are aware of any potential presence of flammable gases. Ensure that the leak detection equipment used is suitable for flammable refrigerants, such as being spark-free, fully sealed, or intrinsically safe.

15) Placement of fire extinguishers ⚠

- When performing hot work on the refrigeration system or related components, an appropriate fire extinguisher must be placed nearby. The refrigerant charging area must be equipped with a dry powder or carbon dioxide fire extinguisher.

16) No open flames allowed ⚠

- When working on an exposed pipeline that contains or has previously contained flammable refrigerant, any form of ignition source that could cause fire or explosion must not be used. All ignition sources, including smoking, must be kept away from areas where installation, repair, relocation, or disposal is being performed if there is a possibility of flammable refrigerant being released into the surrounding environment. When operating on exposed pipes that contain or have previously contained flammable refrigerant, any form of ignition source that could cause fire or explosion must not be used. "No Smoking" sign should be posted.

17) Ventilated area ⚠

- Ensure that the work area is open or sufficiently ventilated before opening the system or performing hot work. Maintain ventilation throughout the entire work process. Ventilation will safely dilute any leaked refrigerant and quickly disperse it into the atmosphere.

18) Inspection of refrigeration equipment ⚠

- If replacing electrical components, they must be installed according to their intended use and in accordance with correct operational specifications. At all times, the manufacturer's maintenance and repair guidelines must be followed. If in doubt, please consult the manufacturer's Technical Department.
- The following inspection items apply to the installation of air conditioners using flammable refrigerants:
 - ① The refrigerant charge amount should be determined according to the size of the room containing components with refrigerant;
 - ② The ventilation equipment should be operating normally, and the air vents should be unobstructed;
 - ③ If an indirect refrigeration cycle is used, check for the presence of refrigerant in the secondary circuit;
 - ④ The labels on the air conditioner should be clear and visible; Unclear signs and symbols should be corrected;
 - ⑤ Refrigerant pipelines or electrical components must not be installed in environments containing substances that could corrode refrigerant-containing components, unless the electrical components are made of corrosion-resistant materials or appropriate anti-corrosion measures have been implemented.

19) Inspection of electrical installations ⚠

- Maintenance and repair of electrical components should include initial safety inspection and component inspection procedures. If safety-threatening defects are found, the appliance must be disconnected from the power supply until the defects are properly addressed. If the defect cannot be completely eliminated and the operation must continue, appropriate temporary measures should be taken. Report this situation to the owner of the equipment and issue warnings to all relevant personnel.

- The initial safety inspection should include: capacitor discharge: it should be carried out in a safe way to avoid sparks; there are no exposed electrical components and wiring during the charging, recycling, and cleaning of the system; continuity of grounding.

20) Repair of sealing elements

- When repairing sealing elements, the power supply to the equipment must be disconnected before opening the sealed cover. If a power supply is required during repairs, continuous leakage detection must be performed on the most hazardous areas to prevent potentially dangerous situations.
- The following repairs on electrical components should be performed with special care to avoid repair methods that compromise the enclosure's protection rating. Improper repair methods may lead to hazards such as damaged cables, excessive connections, terminals not installed according to original specifications, damaged seals, or incorrectly installed seal covers.
- Ensure the equipment is installed securely and safely.
- Ensure that seals or sealing materials will not lose their ability to prevent flammable gases from entering due to aging. Replacement parts must meet the manufacturer's specifications.

Remarks: The use of silicone-based sealants may reduce the detection capability of leak detection equipment. Intrinsically safe components do not need to be isolated before operation.

21) Repair of intrinsically safe components

- No permanent inductive or capacitive loads shall be used in the circuit if it cannot be ensured that the equipment will not exceed the permitted voltage and current limits during operation.
- Intrinsically safe components are the only components that may continue to operate within a flammable gas environment. The test instrument must be set to the correct range or setting.
- If only the components specified by the manufacturer can be used for replacement, since other components may cause refrigerant leakage in the air to catch fire.

22) Cable

- Check whether cables are subject to abrasion, corrosion, overvoltage, vibration, sharp edges, or other adverse environmental influences. This inspection should also consider the effects of aging and continuous vibration from the compressor or fan on the cables.

23) Inspection of flammable refrigerant

- Refrigerant leak inspection must be carried out in an environment free of potential ignition sources. Halogen probes (or any other detectors that use an open flame) must not be used for detection.

24) Leak detection methods

- For systems containing flammable refrigerants, the following methods of leak detection are acceptable:
 - Electronic leak detectors can be used for detecting flammable refrigerants, but their sensitivity may not meet requirements, or they may need to be recalibrated. (Calibration of the instrument should be performed in an environment free of refrigerant.) Ensure that the leak detector does not become a potential ignition source and that it is suitable for the refrigerant being tested. The leak detector should be set to the lower flammable limit (LFL) of the refrigerant (expressed as a percentage), calibrated with the refrigerant being used, and adjusted to an appropriate gas concentration testing range (up to a maximum of 25%).

- The fluid used for leak detection is suitable for most refrigerants; however, ammonia-containing solvents must not be used to prevent reactions between ammonia and refrigerant, as well as corrosion of copper pipes.
- If there is suspicion of leakage, all open flames must be removed from the area or extinguished.
- If welding is required at the location of a leak, all refrigerant must be recovered, or the refrigerant must be completely isolated to a section away from the leak point (using globe valves). Before and during welding, the system must be purged with oxygen-free nitrogen (OFN).

25) Removal and vacuuming

- When performing repair or other operations on the refrigeration circuit, standard procedures must be followed. However, the flammability of the refrigerant must also be given special consideration, and the following procedures must be followed:
 - ① Remove refrigerant;
 - ② Purify the pipeline with inert gas;
 - ③ Vacuum;
 - ④ Purify the pipeline again with inert gas;
 - ⑤ Cut the pipeline or weld it.
- The refrigerant must be recovered into an appropriate recovery cylinder. The system must be purged with oxygen-free nitrogen to ensure safety. This process may need to be repeated several times. This operation must not be performed using compressed air or oxygen.
- During the purging process, anaerobic nitrogen is filled into the system to reach the working pressure under the vacuum state of the system, then the anaerobic nitrogen is discharged into the atmosphere, and finally, the system is vacuumed. Repeat this process until all refrigerant is cleared from the system. After the final charge of oxygen-free nitrogen, the gas is exhausted to atmospheric pressure, and the system can then be welded. The above procedures are essential when performing pipeline welding operations.
- Ensure there is no open flame near the vacuum pump's exhaust outlet and that the area is well ventilated.

26) Refrigerant charging procedure

- In addition to the standard procedures, the following requirements shall be added:
 - Ensure that cross-contamination between different refrigerants does not occur when using refrigerant charging equipment.
 - The refrigerant charging pipelines should be as short as possible to minimize the residual refrigerant within them;
 - The storage cylinder must be kept upright;
 - Ensure that the refrigeration system has been properly grounded before charging with refrigerant;
 - Label the system after refrigerant charging is completed (or even if not yet completed);
 - Care must be taken to avoid overcharging;
 - Perform a pressure test using oxygen-free nitrogen before recharging the system. A leak test must be performed after charging is completed and before the test run. A leak test should be conducted again when leaving the area.

27) Scrapping

- Before carrying out this procedure, the technician should be fully familiar with the equipment and all its characteristics. It is recommended to implement safe refrigerant recovery practices. If recovered refrigerant is to be reused, samples of the refrigerant and oil should be analyzed before performing the operation. Ensure that the required power supply is available before conducting the test.
 - a. Be familiar with the equipment and operation;
 - b. Disconnect the power;
 - c. Before performing this procedure, ensure that:
 - If required, mechanical operating equipment should be readily available for operating refrigerant cylinders;
 - All personal protective equipment (PPE) must be effective and used correctly;
 - The entire recovery process must be carried out under the supervision of qualified personnel; recovery equipment and storage cylinders must comply with applicable standards.
 - d. If possible, vacuum the refrigeration system;
 - e. If a vacuum cannot be achieved, refrigerant should be extracted from multiple points to remove refrigerant from all parts of the system;
 - f. Ensure that the storage cylinder has sufficient capacity before starting the recovery process;
 - g. Start and operate the recovery equipment according to the manufacturer's operating instructions;
 - h. Do not overfill the storage cylinder (liquid charge must not exceed 80% of the cylinder's capacity);
 - i. Even for short durations, the maximum working pressure of the storage cylinder must never be exceeded;
 - j. After completing the cylinder filling and at the end of the operation, ensure that the storage cylinder and equipment are promptly removed, and all globe valves on the equipment are closed;
 - k. Recovered refrigerant must not be introduced into another refrigeration system until it has been purified and tested.

28) Identification

- After the appliance has been scrapped and the refrigerant fully evacuated, it must be labeled with a date and signature. Ensure that the markings on the appliance clearly indicate the presence of flammable refrigerant contained within.

29) Recovery

- Refrigerant must be removed from the system during maintenance or disposal, and it is recommended to completely eliminate the refrigerant.
- When transferring refrigerant into a storage cylinder, only dedicated refrigerant cylinders must be used. Ensure that the storage cylinder capacity is suitable for the total refrigerant charge of the entire system. All cylinders intended for refrigerant recovery must be designated and clearly labeled for that specific refrigerant (i.e., dedicated refrigerant recovery cylinders). The storage cylinder must be equipped with a pressure relief valve and globe valve, both in good working condition. If possible, empty storage cylinders should be evacuated and kept at ambient temperature before use.
- The recovery equipment must be maintained in good working condition, accompanied by readily accessible operating instructions, and suitable for the recovery of flammable refrigerants. In addition, a calibrated and properly functioning weighing device must be available. Hoses must be connected using leak-proof, detachable

couplings and maintained in good condition. Before using the recovery equipment, check that it is in good condition, properly maintained, and that all electrical components are sealed to prevent fire hazards in the event of refrigerant leakage. If in doubt, please consult the manufacturer.

- Recovered refrigerant must be stored in suitable cylinders with appropriate shipping instructions and returned to the refrigerant manufacturer. Do not mix refrigerants in the recovery equipment, especially in the storage cylinder.
- When removing the compressor or clearing compressor oil, ensure that the compressor is evacuated to an appropriate vacuum level to guarantee that no residual flammable refrigerant remains in the lubricating oil. Vacuum pumping shall be performed before the compressor is returned to the supplier. Only electric heating methods are permitted to heat the compressor housing to accelerate this process. When oil is discharged from the system, safety must be ensured.

● Selection of Installation Location

Outdoor Unit

1. The outdoor unit should be placed in a place that is less exposed to rain and direct sunlight (if it is unavoidable, please install shelter facilities); when the unit is placed in a place with obstacles such as a balcony, a space of at least 1.5 meters should be reserved above the unit. Otherwise, the duct should be equipped with the unit.
2. The noise generated by the unit should not affect the neighbors.
3. It is convenient to connect the power supply and the piping of the indoor and outdoor units.
4. Never install in a place where flammable gas may leak.
5. When installed at a high position from the ground, the legs of the unit should be firmly fixed.
6. The load supporting surface must be strong enough to withstand dynamic, static loads of outside unit; neither additional vibration nor noise should be added to avoid affecting the surrounding environment.
7. A certain space should be left to ensure the normal operation of the unit and facilitate installation and maintenance (see the figure below).
8. This air conditioner is not suitable for the following places:
 - a. Vehicles and ships.
 - b. Places with heavy oil smoke or sandstorms.
 - c. Places with high humidity, such as bathrooms, basements, etc.
 - d. There are high-frequency facilities such as radio units, electric welding machines, and medical units.
 - e. Other special circumstances.

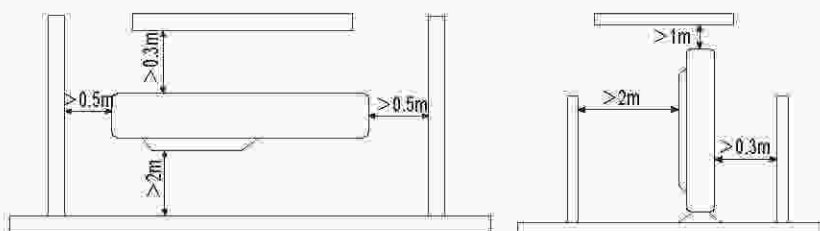

Indoor Unit

1. A location that provides sufficient space for installation and maintenance (see figure below).
2. On a vertical wall with a structure strong enough to support the weight of the indoor unit.
3. Where air intake and exhaust are unobstructed and least affected by external air.
4. Where the airflow can reach all areas of the room.
5. Where the connecting pipes and drain hose can be easily routed out.
6. Away from locations with direct radiation from heat sources.

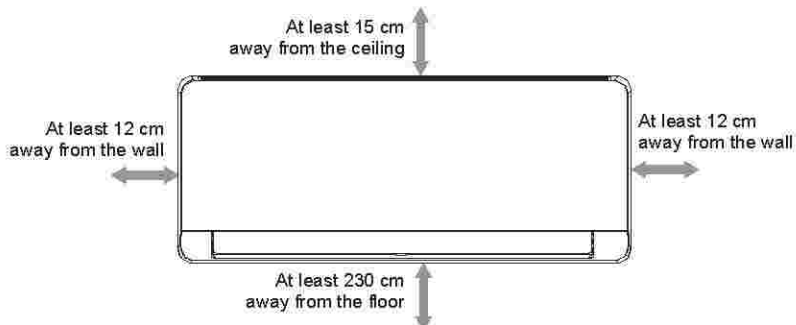

CAUTION

- Air conditioner installation is specialized work and must not be performed by unqualified personnel.
- Wiring methods may vary for different models. Please connect according to the actual provided cables. It is strictly prohibited to alter the cable structure or intended use. For specific wiring connections, refer to the wiring label on the unit.

Indoor Unit Installation

Indoor Unit Installation Dimension Diagram (Unit: mm)

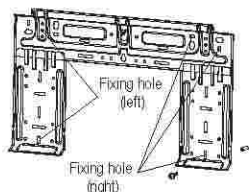
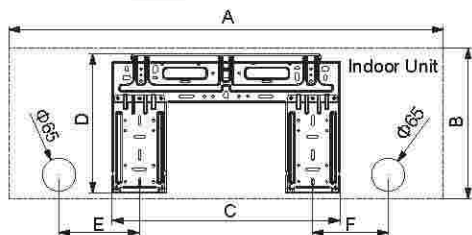

The mounting plate must be secured with two screws on the left side and three screws on the right side, for a total of no fewer than five screws.

Model \ Dimension code	Outline and installation position dimensions						Net weight (kg)
	A	B	C	D	E	F	
42NVAA010	715	295	396	272	105	95	8.6
42NVAA013	864	300	453	277	143	113	9.6
42NVAA018	972	320	619	294	121	95	11.3
42NVAA024	1080	335	701	313	115	118	14.0

TIP

- The diagrams in this Manual are for illustration only, and the actual product shall prevail.

Installation of the indoor unit

WARNING

- The air conditioner must be installed in a location with sufficient strength to support its weight. When necessary, take reinforcement measures. However, if the strength is insufficient, the air conditioner may fall and cause personal injury.
- Perform specific installations to prevent strong winds or earthquakes. An unstable installation may cause the air conditioner to fall or drop, potentially resulting in accidents.
- Before wiring or piping, ensure that the installation area (wall, ground, etc.) is safe without hidden dangers such as water, electricity, and gas.

Installation requirements

1. Choose a location with good indoor ventilation; installation is prohibited in the following places: During installation, please follow the rules below (see left figure);

Wide cooling range

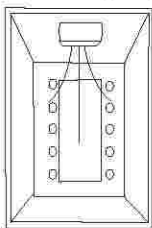

✓ Allowed

Narrow cooling range

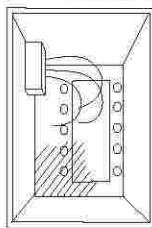

✗ Prohibited

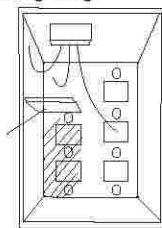

✗ Prohibited

Indoor unit

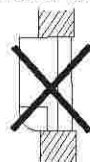

2. Do not embed the unit into the wall (see right figure);
3. Ensure the wall is sturdy.

Main Unit Installation

1. Securing the indoor unit mounting plate

- ① After selecting the mounting location, remove the mounting plate from the back of the indoor unit and place it at the predetermined position. Ensure it is level and maintains adequate clearance from the ceiling and side walls. Mark the positions for drilling the wall mounting holes.
- ② If the wall is made of brick, concrete, or similar material, drill a hole with a diameter of 5 mm in the wall. After drilling the mounting holes with a hammer drill, insert plastic anchors and secure the mounting plate to the wall using self-tapping screws. And use a level to ensure the mounting plate is horizontally aligned.
- ③ Secure the indoor unit mounting plate to the wall.

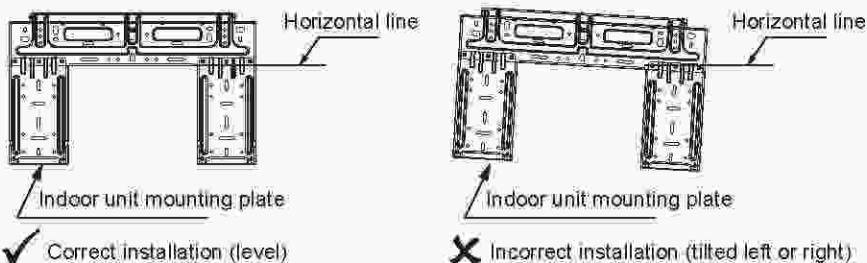

2. Drilling wall holes

- ① Determine the routing direction and outlet position for the piping.
- ② Select the appropriate drill bit according to the model, and use a hammer drill or core drill to drill the through-wall hole.
- ③ When drilling holes, avoid areas with electrical wires, obstacles, or excessively hard sections in the wall. The inner side of the hole should be 0.5 cm to 1 cm higher than the outer side to facilitate drainage. If the through-wall hole is on the side of the indoor unit, it should be slightly lower than the bottom of the unit. When using a core drill, apply plastic sheeting to the wall or take other measures to prevent water from running down the wall. When using a hammer drill, take appropriate dust control measures.

3. Installation structure of the indoor unit

- ① When installed on wooden structures
 - A. Ensure the wooden wall is sufficiently sturdy before installation.
 - B. Determine the vertical position of the mounting plate based on the distance between the indoor unit and the ceiling.
 - C. Adjust the left and right distances centered on the screw holes of the mounting plate.
 - D. Secure the mounting plate to the wall using screws.
 - E. Since the wall thickness is only 25 mm to 45 mm, open the bottom cover, ensure there is no gap between the indoor unit and the wall, and secure it with screws.
- ② When installed on a concrete structure
 - A. Drill holes in the wall according to the mounting plate positions and insert plastic anchors.
 - B. Secure the mounting plate with screws. (See below figure)

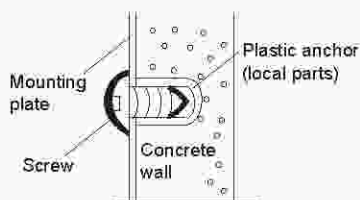

③ Hang the indoor unit

- A. Pass the bundled pipes and connecting wires through the through-wall hole, taking care to prevent damage to the bell-mouth and to keep dirt or debris from entering the connecting pipes.
- B. Hang the upper clips on the back of the indoor unit onto the upper hooks of the mounting plate, and move the unit left and right to check if it is securely attached.
- C. Push the lower part of the indoor unit toward the wall, then move the unit up, down, left, and right to verify it is securely and firmly attached.
- D. Use a spacer block made of cardboard to prop up the indoor unit between the unit and the wall. Remove this spacer block after the piping installation is completed. Continue until the indoor unit is securely hung, ensuring the clips are fully engaged in the slots. When shaken by hand, the unit should not move up, down, left, or right. Use a level to verify that the indoor unit is horizontally aligned.
- E. Piping routing mode:

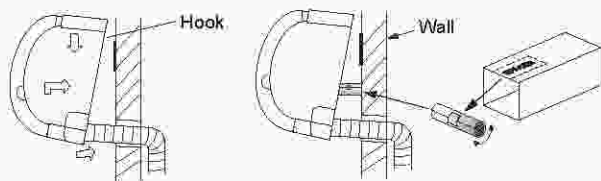

For the rear-left, bottom left and left piping

Cut out a piece of SPACER from indoor unit packaging box, roll it and insert between the indoor unit and wall to tilt the indoor unit for better operation.

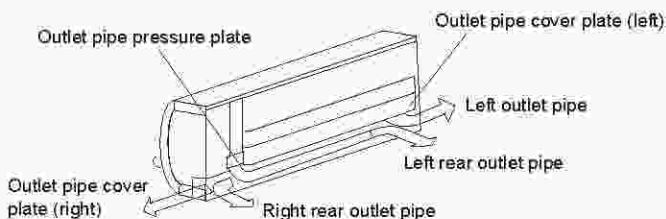

Pipe layout and wrapping

1. Wrap the wiring and piping in the following order: power cables and signal cables on the top side, connecting pipes in the middle, and water pipes on the bottom side.
2. Determine the water outlet position and connect the drain pipe.
3. Do not pull forcefully on the drain pipe when bundling.
4. When extending the piping, secure it at 5 to 6 locations using vinyl tape.
5. When the piping is extended horizontally, insulating material should be applied to cover it.
6. When bundling, avoid covering the refrigerant line joints to allow for leak inspection.
7. When the drain pipe is not long enough and needs to be extended, ensure the indoor section of the extension is covered with protective tubing; the drain pipe joint must be sealed with universal adhesive, and the drain pipe must not have any kinks or coils at any location.

CAUTION

- Do not allow the piping to protrude from the back of the indoor unit.

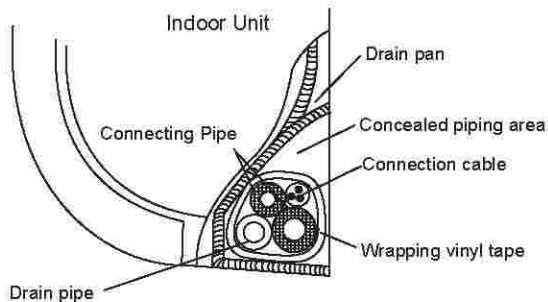

CAUTION

- Please use the mounting plate to determine the indoor unit's mounting position. When refrigerant piping passes through a metal wall, a wall sleeve must be used.

Pipe Layout and Wrapping

CAUTION

- Please strictly follow this installation manual for the drain pipe connection. To prevent condensation, the drain pipe must be properly insulated.

1. The PVC drain pipe has an inner diameter of 20 mm. Users can purchase a drain pipe of suitable length from the dealer or local air conditioning after-sales service center at the time of purchase, based on actual installation requirements, or directly from the market.
2. Connect the drainage system as shown in the figure below.

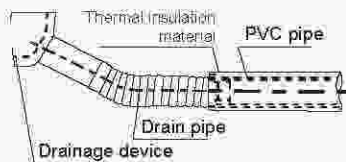

⚠ CAUTION

- Do not apply excessive force to avoid cracking the drain pipe.

3. Wrap the pumping coupling of the main unit and the drain pipe (especially the indoor part) with an insulating bushing evenly, and tighten with a girdle to prevent air from entering and causing condensation.
4. To prevent water from flowing back into the air conditioner when it is turned off, the drain pipe should slope downward toward the outside (drainage side) with an inclination of at least 1/100. Avoid any upward bends or low spots where water can collect (see figure below).
5. When connecting the drain pipe, avoid pulling forcefully to prevent stress on the unit. Additionally, provide a support point every 0.8 to 1.0 meters to prevent sagging or bending of the drain pipe.
6. When connecting an extended drain pipe, cover its indoor section with protective tubing and ensure the extension is securely fastened to prevent disconnection.

⚠ CAUTION

- All joints of the drainage system must be sealed to prevent leakage.

7. The end of the drain pipe should be more than 50 mm higher than the floor or the bottom of the drain tank and should not be placed in water. When releasing condensed water directly into a stinking ditch, the drain pipe must be made to bend upwards into a U-shaped water seal to prevent the stink from entering the room through the drain pipe.
Note: The highest point of the U-shaped water seal must be lower than the height of the drain outlet to avoid obstructing drainage.

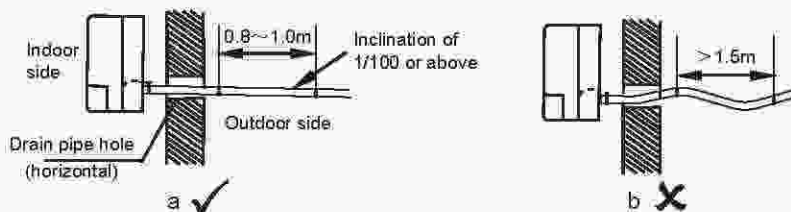

Drainage Test

After installing the drain pipe, pour a small amount of water into the water pan to check if the drainage is smooth and unobstructed.

Installation of the air cleaner

The air cleaner needs to be installed on-site before use. The installation method is as follows:

1. Open the front panel of the indoor unit and take out the filter as shown in (a) below;
2. Insert the air cleaner into the slot in the middle of the air filter, as shown in (b) below;
3. Install the filter in the indoor unit, and then close the front panel.

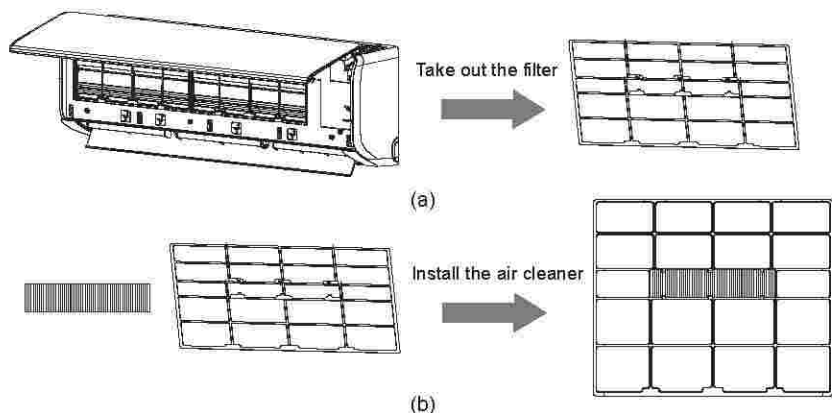

Outdoor Unit Installation

● Outdoor unit installation dimension diagram (unit: mm)

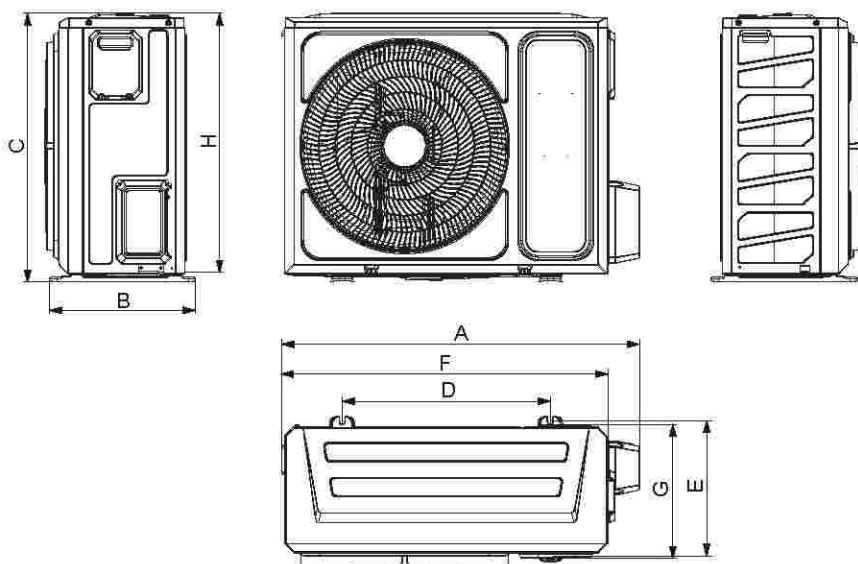

Dimension Code Model	Overall Dimensions			Installation Dimensions		Body Dimensions			Net weight (kg)
	A	B	C	D	E	F	G	H	
38NVAA010	805	305	495	450	285	740	265	480	19.1
38NVAA013									19.3
38NVAA018	880	345	555	510	315	800	300	530	25.0
38NVAA024	935	395	700	545	355	850	345	675	33.1

The space required for the installation and maintenance of the outdoor units: see the following figure for details.

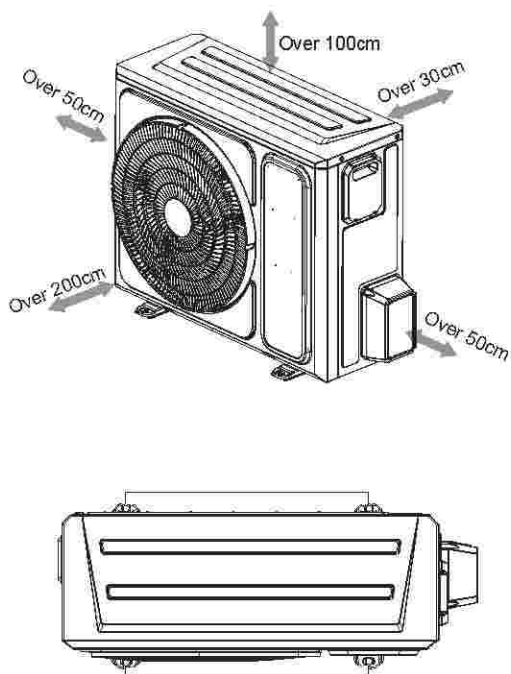

If not using a bracket, simply secure the four base feet of the unit with anchor bolts (four bolts in total, one for each corner) to prevent vibration and noise.

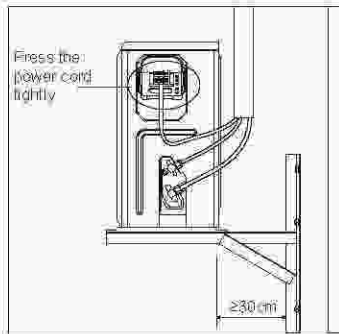

If using a bracket for fixation, in addition to the above body fixation, the bracket and other related requirements must be fixed according to the following instructions, see below:

1. Number of expansion bolts for securing the bracket: 6 bolts for air conditioners of 2 HP and below, and 8 bolts for air conditioners above 2 HP.
2. After all nuts are installed, they must be tightened with a wrench and leak-checked as required to prevent refrigerant leakage.
3. Secure the cable clamp with two screws to firmly press down the power cord and prevent the cable from coming loose.

● Lifting of the equipment

1. Each air conditioning unit has undergone strict inspection and testing before leaving the factory to ensure its performance and quality. Therefore, great care must be taken during equipment installation, especially to avoid damaging the control system and pipeline.
2. The indoor and outdoor units have a left-right orientation distinction when being installed on site. When the indoor or outdoor unit is large in size or access is restricted, making manual handling difficult, lifting may be considered. General requirements for lifting:
 - a. The inclination of the outdoor unit cannot exceed 20 degrees.
 - b. During lifting, the load-bearing parts of the equipment must be separated from the lifting slings by cloth or other soft materials to prevent damage to the equipment.
 - c. During lifting, the equipment must be raised and lowered gently, and the load-bearing points must be evenly distributed to ensure uniform force application.
3. The following methods can be referenced for equipment lifting:
 - a. Manual lifting, forklift lifting.
 - b. Equipment can also be moved by placing logs (or pipes) underneath and manually pushing it forward.
4. Fixation of the equipment. After the equipment has been lifted, the following tasks must be carried out:
 - a. After the equipment has been lifted and placed on the foundation, adjust the equipment's horizontality with a level gauge, with an error not exceeding 0.1%.
 - b. After the equipment is leveled, it can be secured, and the fasteners must be evenly stressed.

Connection and installation of refrigerant piping for indoor and outdoor units

Pipeline Inspection

Check the pipes before connection, and install the pipes if they meet the following requirements:

- The pipes must be clean internally and free of dirt.
- The bell-mouths and nuts at both ends must be intact and free of defects.

WARNING

- During the installation of connecting pipes, prevent air, dust, and other foreign matter from entering the piping system.
- The connecting pipes can only be installed after the indoor and outdoor units are securely fixed.
- When installing the connecting pipes, ensure they remain dry and prevent moisture from entering the piping system.
- The connecting copper pipes must be wrapped with insulation material (usually with a thickness of more than 10 mm, and appropriately thickened in enclosed damp areas).

Steps for connecting pipes

1. Measure the required length of the connecting pipes and fabricate them according to the following methods (refer to the "Pipe connection" section for details).

- Connect the indoor unit first, then connect the outdoor unit.
 - Carefully bend and route the piping, ensuring not to damage the piping or its insulation;
 - Before tightening the flare nut, apply refrigeration oil to the outer surface of the pipe flaring and the conical surface of the connecting nut (refrigeration oil compatible with the refrigerant of this model must be used), and first tighten it by hand for 3 to 4 turns (see the figure below).

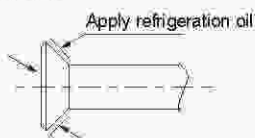

- When connecting or removing piping, two wrenches must be used simultaneously;
 - Do not allow the weight of the connecting pipes to be supported by the indoor unit's connection ports, as excessive force on the indoor unit's pipe connections may cause deformation, which may affect cooling performance.
- During the installation of connecting pipes, the globe valves on the outdoor unit should be fully closed (as in the factory default state). Each connection should be made by unscrewing the nut at the globe valve and immediately connecting the flared pipe (within 5 minutes). If the globe valve nut is removed and left open for an extended period, dust and other foreign matter may enter the piping system, which could cause malfunctions during air conditioner operation.

③ After the refrigerant piping is connected to the indoor and outdoor units, follow the procedures in the "Vacuuming" section to remove air. After degassing, tighten the service nut.

a. Precautions for flexible piping sections:

(1) The bend should be located as close to the center of the pipe length as possible, and the bending radius should not be less than $3.5D$ (where D is the pipe diameter);

(2) Do not bend the flexible pipe back and forth more than three times.

b. Curved thin-walled connecting pipes:

(1) When performing a bending operation, cut out the required amount of notch in the insulation at the bend, then expose the pipe (after bending, wrap it back up with tape);

(2) The bending radius should be as large as possible to prevent the pipe from flattening or being crushed;

(3) Make a tight bend with a pipe bender.

c. Use commercially available copper pipes:

When using commercially available copper pipes, it is essential to use thermal insulation material (typically 10 mm thick or above, and thicker in enclosed or humid areas as appropriate).

2. Pipe layout

① Bend the pipe or drill wall holes as required by the actual installation conditions. The deformed cross-sectional area of the pipe due to bending must not exceed $1/3$ of the original pipe's cross-sectional area. Where pipes pass through walls or floors, protective sleeves must be installed, and welds must not be located inside the sleeves. When pipes pass through exterior wall holes, the holes must be sealed, and the pipes must be tightly wrapped with tape to prevent impurities from entering the pipe. The pipe must be insulated with appropriately sized insulation tubing.

② The bundled connecting pipes should be fed through the wall sleeve from the outdoor unit side into the indoor side. Pipes must be arranged carefully. Do not damage the piping

● Pipe connection

When connecting the refrigerant pipes to the indoor unit, the operation should be performed quickly. During on-site installation, the connection operation time for two pipes must not exceed 5 minutes.

Flaring

1. Cut the piping with a pipe cutter (as shown in the bottom left figure);
2. Insert the pipe into the connecting nut and form a flare at the end of the pipe (see table on the right).

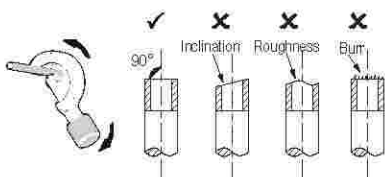

Outer Diameter (mm)	A(mm)	
	Maximum	Minimum
Φ6.35	8.7	8.3
Φ9.52	12.4	12.0
Φ12.7	15.8	15.4
Φ15.88	19.0	18.6
Φ19.05	23.3	22.9

- a. When connecting the flare joint, ensure the two pipes are perfectly aligned and concentric. Then slide the nut onto the pipe and screw it in, finally tightening with a wrench. Refer to the bottom left figure.

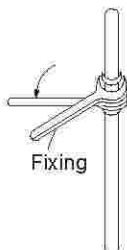

Pipe diameter (mm)	Tightening torque(kgf·m)
Φ6.35	1.4~1.8
Φ9.52	3.3~4.1
Φ12.7	5.0~6.2
Φ15.88	6.3~7.7
Φ19.05	11.2~13.6

⚠ CAUTION

- Please use two wrenches: one standard wrench and one torque wrench. Please refer to the table parameters to determine the tightening torque.
- According to the installation conditions, too large torque will damage the bell mouth, and too small torque will not tighten securely, resulting in an air leak. When connecting copper pipes, adjust the torque wrench according to the tightening torque parameters in the upper-right table before proceeding with the operation.

- b. Through-wall: Indoor and outdoor unit pipes must be equipped with a through-wall bushing when they are inserted through the walls, to protect the pipes and conductors, as shown in the figure below:

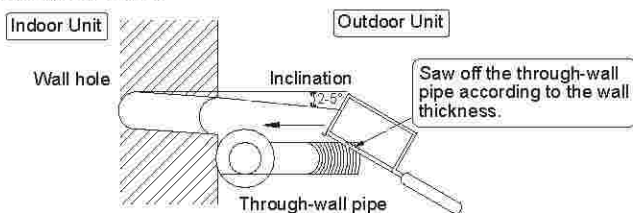

(Cross-sectional drawing of the through-wall hole)

Air Tightness Test

After installation of the refrigerant piping and before connection to the outdoor unit, nitrogen must be injected simultaneously from both the gas side and liquid side at a pressure of 4.0 MPa to perform an airtightness test.

Vacuum Pumping

1. Use a vacuum pump with a vacuum degree below -0.1 MPa and a pumping speed of 40 L/min or higher.
2. The outdoor unit does not require vacuuming. Do not open the outdoor unit's gas side and liquid side globe valves before removing the vacuum pump and pressure gauge.
3. Confirm that the absolute pressure can be reduced to below 30 Pa after the vacuum pump has been operating for 15-20 minutes. If, after 30 minutes of operation, the absolute pressure still fails to drop below 30 Pa, it indicates that moisture has entered the system or there is a leak, which requires inspection.
4. The vacuum pump must be equipped with a check valve.

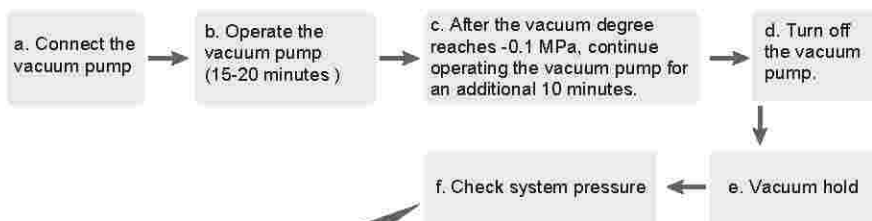

- ① If the pressure change is no more than 20 Pa, the vacuuming is complete. After removing the vacuum pump and pressure gauge, open the outdoor unit valves to perform a test run.
- ② If the pressure change exceeds 20 Pa, please recheck for leaks and perform vacuuming again.

CAUTION

- Where the refrigerant is in direct contact, special tools and instruments for the refrigerant (R32) should be used.
- Never use refrigerant gas for air removal.
- Consider the possibility of leakage when the vacuum degree does not reach -0.1 MPa. Check again if there are any leaks. If no leak is detected, operate the vacuum pump for an additional one to two hours, then repeat steps d to f.

Valve operation

Open and close the valve core of the outdoor unit using a 5 mm hex wrench.

Leak detection

During leak detection, check for leaks at the valve interfaces of the piping connection parts with soap bubbles.

Insulation

After passing the pipeline leak detection and pressure test, the insulation layer can be wrapped. The insulation layer must meet the following requirements:

- a. The pipeline insulation layer must be tightly wrapped, and cracks are not allowed.
- b. The thickness should not be less than 8 mm.
- c. After the insulation layer is wrapped, the outer surface must be treated for waterproofing and moisture resistance (typically bundled with a cable tie externally).
- d. During the cooling operation of the air conditioning system, condensation on the outer surface of the connecting copper pipes is absolutely not allowed.

Refrigerant top-up quantity (R32)

1. Precautions for refrigerant top-up

- No refrigerant top-up is required if the connecting pipe length does not exceed 7.5 meters. Refrigerant must be topped up according to the table below if the length exceeds 7.5 meters.
- Refrigerant must be topped up in liquid form, and the charging process must be measured using calibrated measuring equipment.
- If the refrigerant cannot be fully topped up while the outdoor unit is stopped, perform the charging in cooling test run mode.

2. Calculation of refrigerant top-up quantity

- Determine the refrigerant top-up quantity according to the following calculation method, and record the amount of added refrigerant in the appropriate documentation.
- Refrigerant top-up quantity for piping: $M = (\text{liquid pipe length } L - 7.5) \times \text{refrigerant top-up amount per unit length of pipe}$

Model	Refrigerant top-up quantity per unit length of pipe (g/m)	Length(L-7.5)(m)	Top-up quantity (g)
42NVAA010 38NVAA010	10		
42NVAA013 38NVAA013	10		
42NVAA018 38NVAA018	12		
42NVAA024 38NVAA024	24		

CAUTION

- During installation, the refrigerant sealed in the outdoor unit cannot be used to remove the air inside the pipe, and a vacuum pump is required for vacuuming.

Heat insulation treatment

Insulate the gas side and liquid side piping separately. During refrigeration, the liquid side and gas side piping temperatures are low; therefore, sufficient insulation must be applied to prevent condensation (see figure below).

1. The gas side piping must be insulated with heat-resistant material capable of withstanding temperatures above 120°C.
2. The piping connection parts of the indoor unit must be insulated without gaps using the supplied insulation material.

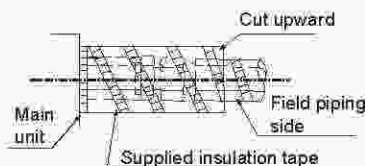

Piping of the pipeline

Due to different air conditioning installation locations, the required piping lengths vary. To avoid reduced cooling capacity caused by excessively long piping, please refer to the table below to reasonably select the pipe length, and install the unit in a location that allows for shorter pipeline whenever possible.

Maximum allowable operating distance for the pipeline

Value \ Model	42NVAA010 38NVAA010	42NVAA013 38NVAA013	42NVAA018 38NVAA018	42NVAA024 38NVAA024
Maximum Length (m)	20	20	20	25
Maximum Height (m)	8	8	10	10

Installation of condensate drain pipe

1. Main considerations for the indoor unit condensate drain pipe
 - a. Large drainage volume of condensate water;
 - b. Cooling capacity loss due to condensation;
 - c. Inconvenient maintenance when installed concealed, and potential for air leakage through this area.
2. The materials for the condensate water drain pipe can be U-PVC pipe and galvanized water pipe. Considering hygiene, rust prevention, and other issues, U-PVC pipes are recommended.
3. Installation requirements:
 - a. The outdoor drain outlet must be equipped with a water seal and securely fixed.
 - b. The slope of the drain pipe should be $\geq 1\%$.

- c. The indoor section of the condensate drain pipe should be fitted with an insulation tube or wrapped with insulation foam.
- d. After the installation of the condensate drain pipe, a water-filling test must be performed to check for leaks. Ensure that all connections are watertight and drainage is smooth. Installation can refer to the figure on the right:

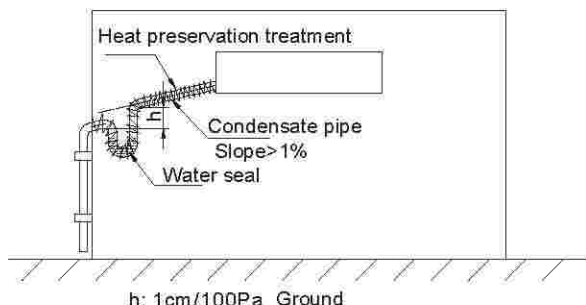

■ Electrical Installation

● Connection between wires and the terminal block

⚠ CAUTION

Before you proceed with the electrical equipment installation, our design personnel remind you to pay attention to the following points:

1. Check whether the power supply used is consistent with the power specified on the nameplate.
2. The power supply capacity must be sufficiently large, and the cross-sectional area of the room wiring should be 2.5 mm² or larger.
3. The wiring must be performed by qualified personnel.
4. Secure the air-break switches in the circuit that must be equipped with leakage protection switches and have an electrode contact spacing greater than 3 mm.
5. Connection of a single branch wire
 - a. Strip off about 25 mm of the insulation layer at the end of the single branch wire with wire strippers.
 - b. Remove the screws from the air conditioner's terminal block.
 - c. Bend the end of the single branch wire into a loop that matches the size of the screw with pliers.
 - d. Pass the screw through the loop of the single branch wire and secure it to the terminal block.
6. Connection of multi-stranded twisted wires
 - a. Strip off about 10 mm of the insulation layer at the end of the stranded wire with wire strippers.
 - b. After stripping, fit the numbered marker tube corresponding to the terminal block number onto the wire. (The numbering for indoor and outdoor units must be consistent)

- c. Crimp a terminal of matching size to the screw onto the end of the stranded wire with crimping pliers.
- d. Remove the screws from the air conditioner terminal block.
- e. Pass the screw through the terminal on the stranded wire and secure it to the terminal block.

Note: For safety, when connecting power cables and interconnecting wires to the terminal block, it is required to crimp on a properly sized terminal!

 **WARNING**

- **The air conditioner must be reliably grounded to prevent hazards caused by insulation failure!**
- The screws securing the wires must be tightened securely; if slipped, they must be replaced!
- External wires must be secured with cable clamps; otherwise, they may result in personal injury or fire!
- For split-power models, the indoor unit and outdoor unit must be separately connected to the same circuit breaker with overload protection and leakage protection, so that turning off the breaker simultaneously cuts power to both the indoor and outdoor units. It is strictly prohibited to supply power to the outdoor unit by drawing wires from the indoor unit's terminal block!
- If the appliance's power cord or signal cable is damaged, it must be replaced with a dedicated cable.
- Before wiring, please identify the voltage of the components indicated on the nameplate, then connect the wires according to the wiring diagram.
- The air conditioner should use a dedicated power cable and must be equipped with a leakage protection switch and an air-break switch to handle potential overload conditions.
- All wiring must use crimped terminals or single wire. Directly connecting stranded wire to the terminal block may cause sparking.
- All wiring must be correctly connected according to the electrical wiring diagram. Incorrect wiring may cause the air conditioner to operate abnormally or become damaged.
- Do not allow the cable to come into contact with refrigerant pipes, compressor, fan, or other moving parts.
- Do not alter the internal wiring of the air conditioner arbitrarily. The manufacturer will not be held liable for any losses or abnormal operation resulting from such modifications.

Power cable connection

1. Remove the plastic handle from the outdoor unit.
2. Connect the power cable to the "L", "N", and grounding terminals.
3. Secure and fasten the power cable with a cable clamp.

Installation of the signal wiring connecting the indoor and outdoor units

Connect the signal wires and power cables according to the unit's wiring diagram.

Wiring diagram of the unit

Refer to the "Wiring diagram" for indoor-outdoor connections of various models. (The schematic diagram is for reference only. Please refer to the wiring nameplate of the unit for wiring.)

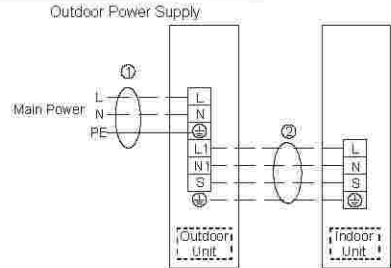

Unit Wiring

Name Model	Power Cable (number × wire diameter, wire length)	Connecting wires (number × wire diameter, wire length)	Selection of an air-break switch	Power supply mode
42NVAA010 38NVAA010	3 × 1.5mm ² , ≤25m	4 × 1.0mm ² , ≤25m	16A (with 16A socket)	Outdoor power supply
42NVAA013 38NVAA013				
42NVAA018 38NVAA018	3 × 2.5mm ² , ≤25m	4 × 1.5mm ² , ≤25m	25A	
42NVAA024 38NVAA024	3 × 2.5mm ² , ≤25m	4 × 1.5mm ² , ≤25m	25A	

⚠ CAUTION

- The cross-sectional area of the wire selected by the user must not be smaller than any of the specifications listed in the table above. If the user's power cable is excessively long from the unit, the cross-sectional area of the wiring should be appropriately increased to ensure proper power supply.

Self-diagnosis Function

Indoor Unit Fault Code Table

Fault definition	Display content of the digital tube light board
Phase error	E0
Communication fault between indoor and outdoor units	E1
T1 sensor fault	E2
T2 sensor fault	E3
T2B sensor fault	E4
Malfunction of outdoor unit	E5
Zero-crossing signal detection fault	E6
EEPROM malfunction	E7
Fan stall protection	E8

Test Run

Electrical safety inspection	Item details	<ul style="list-style-type: none"> Whether the power supply voltage complies with requirements; Whether there are any incorrect or missing connections in the power cables, signal cables, and grounding wires; Whether the grounding resistance and insulation resistance comply with requirements.
Installation safety inspection	Item details	<ul style="list-style-type: none"> Confirm the routing and unobstructed flow of the drain pipe; Confirm that the connections of the connecting piping are properly installed; Confirm the safe installation of the outdoor unit, mounting bracket, and indoor unit; Before operation, ensure that both high-pressure and low-pressure globe valves are fully open, and prevent air or other contaminants from entering the refrigeration system. Confirm that no foreign objects or tools are left inside the unit.
Refrigerant leak detection	Leak detection locations	<ul style="list-style-type: none"> The pipeline interfaces where the indoor unit is connected to the connecting pipe, the pipe interfaces where the two globe valves of the outdoor unit are connected, the valve core, the process port or the welding port, and other parts where leakage may occur.
	Leak detection methods	<ul style="list-style-type: none"> <ul style="list-style-type: none"> Foam test method: Evenly apply (or spray) soapy water or foam onto areas where a leak may occur, and observe for bubble formation. The absence of bubbles indicates a safe, leak-free result. Instrument leak detection method: Detect with a professional leak detector. Position the detector probe at locations where leaks may occur, and make a judgment on the leak detection result according to the instrument's instructions.
	Remarks	<ul style="list-style-type: none"> Each leak detection should be kept for 3 seconds or more; If a leak is detected, tighten the nut accordingly and recheck until no leak is detected. After completing the leak detection, insulate all exposed indoor unit pipeline connections with insulation material and secure them tightly with binding tape to prevent loosening, condensation, and dripping.

End of
installation

- After installation and verification of normal operation, inform the user to carefully read the Installation and Operation Manual before use, demonstrate the air conditioner's operation methods and essential maintenance knowledge to the user, and remind the user to properly store the accessories.
- Explain to the user their rights and responsibilities, clean the work area, and put away tools.

Maintenance

■ Cleaning of the filter and air cleaner

1. Wipe with a soft dry cloth.
2. If stains are difficult to remove, clean with clean water or a neutral detergent.

CAUTION

- The filter and air cleaner can remove dust and other particles from the air. If they become clogged, the air conditioner's cooling capacity will decrease, operating noise will increase, and power consumption will rise. Therefore, during long-term use, please be sure to clean the filter and air cleaner frequently. If installed in a dusty environment, increase the frequency of cleaning the filter and air cleaner; it is recommended to clean them once a month.
- If the dirt is severe and difficult to clean, please replace the filter and air cleaner.
- Do not remove the filter and air cleaner except when cleaning, as this may cause malfunctions.
- Before performing maintenance or repairs, the air conditioner must be turned off and the power plug disconnected.

Cleaning steps

- ① Open the front panel of the indoor unit and remove the air filter

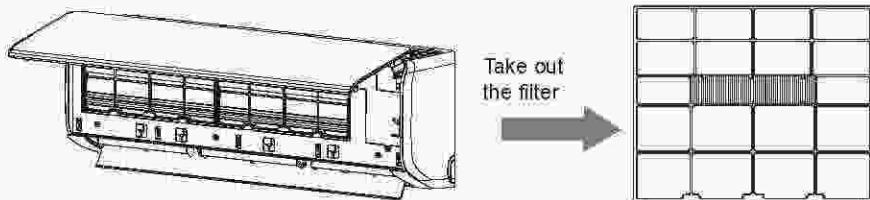

- ② Take out the air cleaner.



③ Clean the filter.

When using a vacuum cleaner, position the filter with the air intake side facing up.

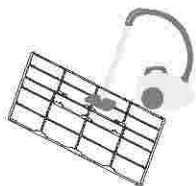

When cleaning with clean water (except for the activated carbon module), position the filter with the air intake side facing down.

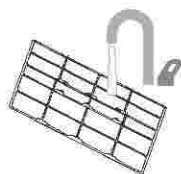

i TIP

- Do not expose the filter and air cleaner to direct sunlight or heat them near a stove, and do not clean them with very hot water (above 40°C), to prevent deformation.
- If the filter and air cleaner are heavily soiled, clean them with a soft brush and neutral detergent, then shake off excess water and dry them in a cool, shaded area.
- It is prohibited for unqualified personnel to remove, replace, or repair the filter and air cleaner.
- It is recommended to clean the filter once a month and use high-pressure air to clean the air cleaner. When the air conditioner is used in a dusty environment, the cleaning frequency should be increased accordingly.
- The air cleaner must not be cleaned with water.
- It is recommended to replace the air cleaner every 3–4 months.

④ Reinstall the filter and air cleaner.

⑤ Reinstall and close the front panel in the reverse order of steps ① and ② described above.

■ Cleaning of the air outlet and external panel

1. Wipe with a soft dry cloth.

2. If stains are difficult to remove, clean with clean water or a neutral detergent.

⚠ CAUTION

- The air conditioner power must be disconnected before cleaning.
- Do not use gasoline, benzene, solvents, abrasive cleaners, or liquid insecticides, as they may cause discoloration or deformation.
- Do not allow water to enter the interior of the indoor unit, as this may cause electric shock or fire.
- When cleaning the air deflector vanes with water, do not scrub forcefully.
- If the air conditioner is operated without the air filter installed, dust in the indoor air will not be removed and will accumulate inside the unit, which may often lead to malfunctions.

■ Maintenance

1. For deep maintenance, have a professional technician clean and service the air conditioner approximately every 2 to 3 years.
2. Generally, clean the indoor unit's filter every three months.
If the operating environment is dusty, the air filter will accumulate dust more quickly, reducing airflow and cooling capacity. In severe cases, excessive dust can completely block the filter, affecting air conditioning performance and indoor air quality.
3. Before storing the air conditioner for a long period of inactivity, please perform the following steps:
 - ① Select the "Air supply" mode and run the indoor unit for a period of time to dry it out.
 - ② When not in use for a long time, disconnect the power to reduce standby power consumption. At the same time, wipe the wireless remote controller clean with a soft, dry, lint-free cloth and remove the batteries.

CAUTION

- Before long-term idling of the air conditioner, the components inside the outdoor unit should be checked and cleaned periodically. For details, please contact the dealer.
- After a long period of idling, check the indoor and outdoor units' return air outlet and air outlet to see if they are blocked. If blocked, clean them immediately.

Appendix

■ Instruction Manual for Remote (NT-02)

● Notice to Users

CAUTION

1. Make sure that the remote control is aligned with the signal receiving window to ensure that there is no obstacle between the two.
2. The operation of the remote control should be within its receiving range.
3. The remote control should be placed more than one meter away from the TV or audio equipment.
4. When the remote control transmits information, the "📶" symbol will flash for about 1 second. When the air conditioner receives the effective remote control information, it will emit a "tick" receiving sound.
5. Do not drop the remote control or throw it around.
6. Do not allow any liquid to flow into the remote control.
7. Do not expose the remote control to direct sunlight or place it in extreme heat.
8. Different air-conditioning units have different functions, and the specific functions are subject to the air-conditioning manual.



Please read this manual carefully before use and keep it properly.
The renderings of the manual are for reference only, and
the specific model is subject to the actual product

Remote

Schematic diagram of appearance

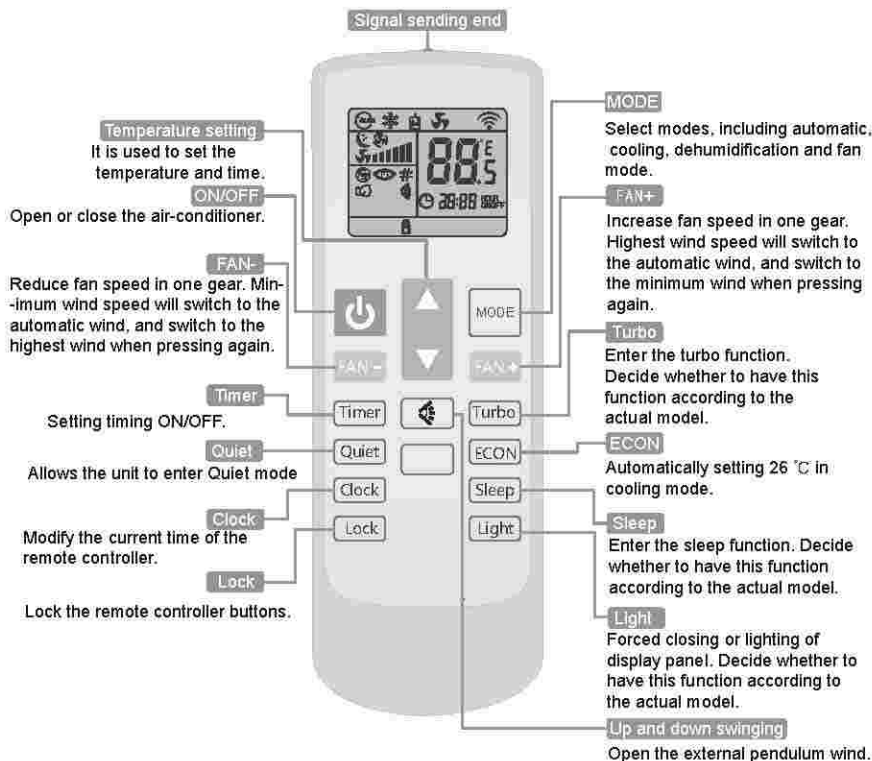



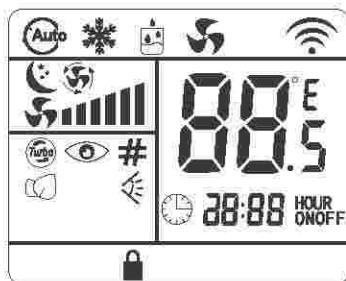













The meaning of the symbols of the remote control



1. When powered on for the first time, the LCD screen of the remote control will first display all the pattern characters, and then enter the standby state, only the clock 12:00 and light will be displayed.

2. The LCD screen icons are introduced as follows:

Mode display			
 Automatic	 Cooling	 Dehumidification	 Fan
Temperature display			
 Temperature displays , which range between 16 ~ 32°C.			
Wind speed display			
 Wind speed	 Automatic wind		
Swinging display			
 External pendulum wind			
Timer display			
 Time on	 Time off		
Other display			
 Clock	 Sleep	 TURBO	 ECO
 Addressing	 Lock		

Description of the function of the remote control

ON/OFF

1. When pressing this button, the remote control presses "on→ off→ on" to switch in a cycle.
2. When the first power on is from "off→ on", the default setting of the working state is: set temperature 25 ° C (77 ° F for Fahrenheit), auto mode, auto wind speed, internal and external damper swing, no power, no sleep, no timing, no lock key.
3. When it is not powered on for the first time, from "off → on", the working state is the state before shutdown; When powered off, the Sleep, Powerful, Energy Saving, and Timer functions are canceled.

Mode

- 1) When the machine is turned on, when this button is pressed, the remote control will press "Auto → refrigeration→ dehumidification→ ventilation → automatic" cycle switching.
- 2) The dehumidification mode is locked at 25°C and is not adjustable.

Temperature Setting

1. When the machine is turned on, press the "▲" button once, and add 1 ° C to the set temperature; Press the "▼" button once to reduce the set temperature by 1 ° C. The temperature setting range is 16~32° C (61~90° F). (The temperature will not change when pressing this button in dehumidification and air supply mode)
2. In the clock setting state (the clock setting status will flash to prompt), it is used to set the clock time.

Up and down swinging (External pendulum wind)

1. During dehumidification mode, the upper and lower swing air is forcibly turned off.
2. In other modes, press "Swing Wind→ Fixed Wind →Swing Wind" when pressing this button.

FAN +

1. The default is automatic wind speed when the first power is on, and the wind speed is fixed as low wind and cannot be adjusted when dehumidification mode, and there is no response when pressing the wind speed button.
2. When pressing this button in other modes, press "Auto Wind→ Low Wind→ Medium Wind→ High Wind→ Auto Wind" to switch cycles.

FAN -

1. When the dehumidification mode is fixed, the wind speed is fixed as low wind and cannot be adjusted, and there is no response when pressing the wind speed button.
2. When pressing this button in other modes, press "Auto Wind→ High Wind→ Medium Wind→ Low Wind, →Auto Wind" to switch cycles.

Timer

1. In the shutdown state, press this button to set the timer on, and the setting time is 1~24h.
2. In the power-on state, press this button to set the timer off, and the setting time is 1~24h.
3. The timing time is "1h→2h→...→23h→24h→ cancel the →1h" cycle.
4. Press without buttons, exit timer adjustment after 3 seconds.

TURBO

1. Some models are available (the extended code remote control is effective), the remote control defaults to no strong state, and the strong button does not work when in automatic mode, dehumidification mode, and ventilation mode (press strong and do not display, no code).
2. Press this button in cooling mode to switch between on and off strongly. When there is a strong wind, the wind speed is not displayed, and the strong operation is turned off after changing modes, and the strong operation is turned off when the sleep operation is set.
3. After pressing this button for the four-speed wind model, the strong icon will light up, and the four-speed wind will be turned on at the same time.

ECON

1. The remote control defaults to no energy-saving state, and the energy-saving button does not work when in automatic mode, dehumidification mode, and ventilation mode (pressing energy-saving does not display, and does not issue codes).
2. Press this button in cooling mode, and the energy saving will be switched between on and off cycles. When there is energy saving, the set temperature is automatically set to 26 ° C, other settings remain unchanged, the previous setting is restored after turning off energy saving, and energy saving is turned off after switching modes.

Sleep

1. In addition to the air supply mode, when pressing the sleep button, press "Sleep → cancel sleep → sleep" cycle switch, and the sleep will be canceled after changing modes.
2. When pressing the sleep button to set sleep, the wind speed will automatically switch to low wind, but the wind speed can be adjusted by pressing the wind speed button (except for dehumidification mode)

Tip: When the indoor environment is very humid, prolonged operation of the machine may cause condensation to form on its body.

Light

1. There is no light board light by default when the first power is on, press this button to force off or light up the display light board, and decide whether this function is available according to the actual model.

Clock

1. Used to set the clock, press this key The hour clock of the LCD screen flashes, indicating that it has entered the clock adjustment state, and the clock can be set with the plus or minus key, and the time value range is "0→1→2→... →21→22→23→0" range loop.
2. After the clock is set, then press the clock button, at this time the minute on the display screen flashes, indicating that it has entered the minute adjustment state, you can use the plus or minus key to set the minute, the score range is "00→01→... →59→00" range loop.
3. After the adjustment, confirm it by the clock button to exit the adjustment state, if it is not confirmed by the clock button, exit the time adjustment state in 3 seconds, and restore the clock before adjustment.

LOCK

1. The default is no lock key state, when pressing this key, the remote control press "lock key→cancel the lock key→lock key" cycle switching.
2. When there is a lock key, all the keys of the remote control will not work except for the child lock key.

Quiet

1. When pressing this button, the machine speed is adjusted to the lowest speed.
2. Quiet mode can be canceled by Fan+, Fan-.

Tip: When the indoor environment is very humid, prolonged operation of the machine may cause condensation to form on its body.

Combinatorial key: "FAN -" + "FAN +"(Available for 6-gear wind unit)

1. The extended code remote control is effective, switch 3 gears/6 gears, the LCD screen is 6 gears, if you switch 3 gears, 1 and 2 gears are lit at the same time as "low wind", 3 and 4 gears are lit at the same time as "medium wind", and 5 and 6 gears are lit at the same time as "high wind".

Combinatorial key: "Mode" + "Lock"(Available for VRF)

1. Enter address setting
 - A. On the shutdown interface, press the combinatorial key on the remote controller for 5 seconds to enter the address setting interface.
 - B. The last address (when the first power on, 00 is displayed) and the "#" icon are displayed and flickering.

2. The step instructions of setting address

- A. At the address setting interface, press the temperature addition or reduction to adjust the setting address, and it ranges from 00 to 63.
- B. When the first time entering the interface or pressing the temperature addition or reduction key, the address display flickers for 3 seconds and then does not flicker.
- C. Press the ON / OFF key to enter the sending state and send the address setting code.

3. The step instructions of inquiring address

- A. At the address setting interface, press the mode key to send the query code.
- B. At this time, the "#" icon flickers. 3 seconds later, it normally displays the last setting addresses and the "#" icon does not flicker.

4. Exit setting

- A. Pressing the mode key and lock key at the same time can exit the address setting interface.
- B. If there is no key pressing associated with address setting for more than 30 minutes, the remote controller will exit the address setting interface.

Battery replacement and precautions

1. If the air conditioner cannot receive the signal from the remote control, and the remote control screen is blurry, it means that the battery is exhausted and needs to be replaced.
2. Gently press the engraved "  " on the battery cover, and push out the remote control battery cover in the direction of the bottom of the remote control; and push out the remote control battery cover towards the bottom of the remote control.
3. Remove the old battery and replace with 2 new No. 7 (AAA 1.5V) dry cell batteries and make sure the positive and negative electrodes are in the correct position.
4. Close the battery cover of the remote control in the opposite direction of the original battery compartment cover.
5. Set the current time.



CAUTION

1. When replacing the battery, do not mix the old and new batteries or different types of batteries, otherwise it may cause the remote control to malfunction.
2. If the remote control is not used for a long time, remove the battery to prevent leakage and damage to the remote control.
3. If the remote control does not work normally, please remove the battery, reinsert it after 30 seconds, if it still does not work properly, please replace the battery.
4. The dry battery that meets the requirements of JIS or IES standards has a service life of 6-12 months under normal conditions.
5. The battery is marked with "Recommended Expiration Date", and the actual use time may be shorter than the recommended time.

802037000319.EV0

The Carrier logo is a black oval with a white border, containing the word "Carrier" in a white, italicized serif font. The logo is centered on the page, surrounded by several semi-transparent, gray, circular bubbles of varying sizes that appear to be floating or rising. The background is white with a light gray curved shape at the bottom right corner.

Carrier